

Effect of Continuous Ohmic Heating on Quality Attributes of Paneer and its Shelf Life Study

ABSTRACT:

The study was aimed to compare the quality attributes of paneer prepared by milk heated using a two-stage continuous ohmic heater with convectional heating. The comparison was based on compositional and textural analysis of freshly prepared paneer as well as the changes occurred in sensory, acidity and microbial parameters during storage at refrigeration temperature. Desired temperature of milk (80°C) was achieved by applying a voltage of 137.7 V in stage-1 and 72.2 V in stage-2, whereas steam was used as a heating medium in conventional method. The composition of paneer was not affected and showed similar values for moisture, fat, protein, lactose and ash content, irrespective of the heating method. Moreover, the values of hardness, cohesiveness, springiness and adhesiveness were slightly lower compared to samples heated using conventional methods, indicating better textural characters of ohmically prepared paneer.

Key words: Ohmic heating, Paneer, Storage study, Quality attributes

1. INTRODUCTION:

India holds the unique distinction of being the world's largest producer and consumer of milk. The nation produced 221.1 million tons of milk in 2021–2022 and 230.6 million tons in 2022–2023; per capita availability was 459 g per day (Anonymous, 2024) (www.nddb.coop). In the current period of rapid technological innovation and growing consumer consciousness regarding the impact of food processing, consumers need minimally processed and fresh-looking foods [1]. Ohmic heating is a promising technology for food processing as it can provide rapid and uniform heating without the need for heat exchangers or steam generators [2]. It provides uniform heating throughout the material by applying an electrical current to a conductor that causes the molecules to vibrate and generate heat. This technology is being increasingly used in the food processing, pharmaceutical as well as chemical industries. In addition to the product quality and safety, microbial destruction is a key parameter to be addressed in food processing applications. High number of undesirable microorganism present in

food products may deteriorate its quality with respect to defects in appearance, odour, taste, colour, etc. and may cause health issues as well. One of the major causes of *Salmonella spp.* outbreaks is considered to be inadequate methods used for cooking [3]. Ohmic processing ensures that each and every particle of food is heated and thus maintains the quality of food with respect to microbial load [4].

In ohmic heating technique, the product doesn't experience a large temperature gradient as it heats. This factor is a major advantage for food applications, thereby avoiding degradation of heat sensitive compounds, changes in taste, undesirable reactions and reducing the fouling of electrode surface [5] [6]. This technology involves a short thermal inertia therefore a fast, simple and precise regulation can be made possible. The heating is rapid and uniform, depth of heat penetration is virtually unlimited, large temperature gradient is usually not experienced within the food are some of the other benefits of ohmic heating, making the process ideal for shear-sensitive products [7]. The aim of this study was to compare ohmic heating method with conventional heating for heating of milk for paneer manufacturing. As the nature of milk is heat sensitive, use of ohmic heating technique may prove effective in terms of product quality. In present study, both the sample of paneer was analysed for physicochemical, textural, sensory and microbial parameters for fresh product as well as during its storage at refrigeration temperature.

2. MATERIAL AND METHODS:

The quality of milk used for the preparation of paneer is of significant concern, with respect to its physico-chemical, microbial, textural as well as sensory characteristics. In the present study, developed ohmic heater was used to heat milk in order to manufacture paneer and their quality characteristics were studied during their storage. The paneer made by using ohmic heated milk was also compared with the paneer prepared using milk treated with conventional heating using steam. The milk having 4.5 per cent milk fat and 8.5 per cent solid not fat was used in preparation of paneer during all experimental trials.

2.1 Continuous Ohmic heater:

An ohmic heater consisting of two heating cells was used for heating and controlling the temperature of milk [8]. One unit of ohmic heating cell consists of two stainless steel pipes. The outer pipe had the inner diameter of 72.04 mm, whereas the inner pipe

with an outer diameter of 25.4 mm was used. The length and thickness used for both the outer pipes was 1.12 m and 3 mm, respectively. The length and thickness used for both the inner pipes was 1.37 m and 3 mm, respectively. Both the pipes were electro polished from inner and outer side. Two balance tanks having the capacity of 60 kg milk was installed to maintain the level in the milk supply tank. Automatic liquid level controller was used for maintaining the level of milk in supply tank by using 'ON and OFF' system in the centrifugal pump when low and high level were reached, respectively. In the designed two stage continuous ohmic heater, six RTD (PT-100) were equipped to check the temperature of milk at inlet, outlet and at various intermediate locations on the pipe. The electric panel was consisting of variac (auto transformer), energy meter, step up transformer, voltmeter (0-500 V AC) and ammeter (0-100 ampere AC) for measuring the current and voltage supplied. Technical drawing of ohmic heater and its electric panel is as shown in Figure 1 and 2, respectively.

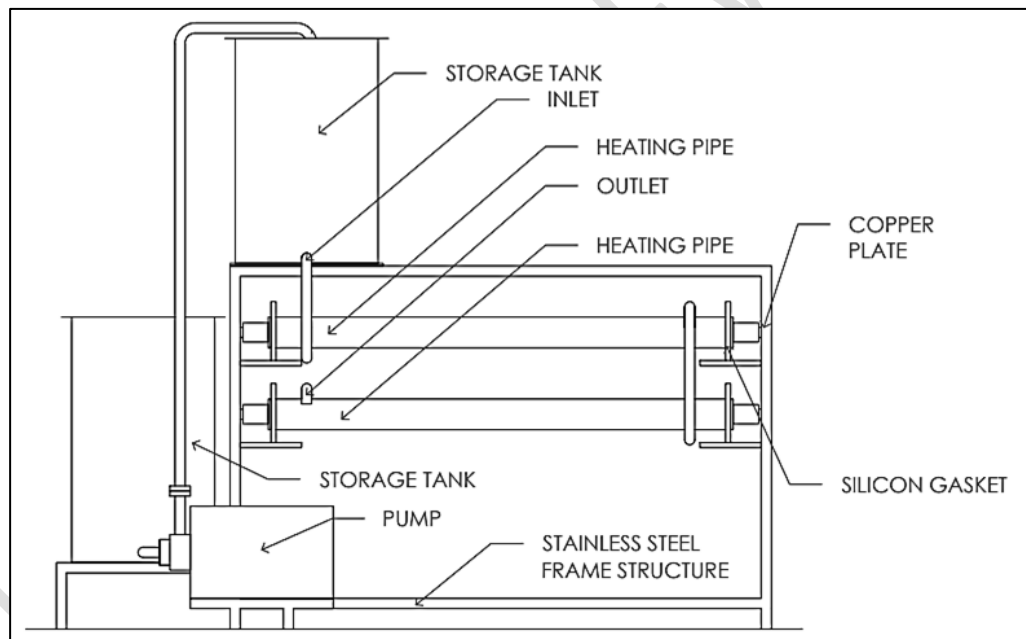

Figure 1: Developed continuous ohmic heater for milk

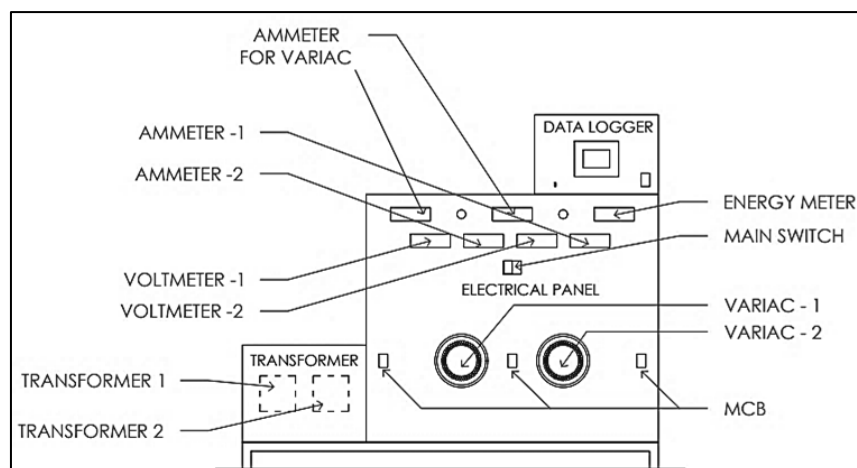

Figure 2: Electrical panel for continuous ohmic heating unit

2.2 Conventional heating: conventional heating of milk was done by using steam jacketed kettle to achieve the desired temperature.

2.3 Packaging Material:

The specifications of packaging material used to store the paneer samples are as mentioned in Table 1.

Table 1: Specifications for packaging material for paneer

Sr. No.	Particulars	Specifications
1.	Material	12 mic PET/50 mic co-ex-poly (N)
2.	Pouch size (H*W) mm	185*125
3.	Thickness (GSM)	86±5%
4.	Bond Strength	225gm/15mm
5.	Sealing strength	≥3 kg/15 mm
6.	Method of packing	Vacuum packing

2.4 Method for Manufacture of Paneer

Milk was filtered through muslin cloth and heated at 80±2 °C without hold using ohmic and conventional methods was used for the preparation of paneer samples using the method of [8]. After heating, the milk was cooled up to 70°C and coagulated using anhydrous citric acid with continuous stirring until clear whey was separated. After the whey separation, 10 min settling time was provided followed by drainage of whey and pressing of curd at 0.5 – 1kg/cm² was done and the paneer blocks were dipped into the

chilled water (4° C). After cutting and slicing process, the prepared samples were packed in LLDPE pouches, sealed and stored at 7±1°C.

2.5 Compositional analysis of paneer

2.5.1 Physico chemical analysis: Moisture content in paneer was determined according to the procedure [10] specified for paneer under IS: 10484. The fat content of paneer samples was determined by the [11]. Protein content in paneer was determined by Kjeldahl method, using Kjel-plus digestion system (Model-KPS 006L) and Kjel-plus semi-automatic distillation system (Model-Distil M) of M/s. Pelican Instruments, Chennai, ash content of all the samples was determined by procedure described in [12]. The effect of ohmic treatment on acidity of paneer was evaluated in all the samples using the procedure of [13]. Total carbohydrate content was estimated by difference method, total Carbohydrate (g/100g) = 100 - [protein + fat + ash + moisture]

2.5.2 Sensory Evaluation: The prepared samples of paneer were subjected to sensory evaluation by panel of six judges using 100 points score card [14].

2.5.3 Microbial analysis: The plating, incubation and counting method to enumerate coliform in paneer samples were followed as described by [15]. Aerobic plate count (APC) of Paneer was determined by method described by [16] and yeast and mold was described by [13]. For coliform count, Suitable dilutions of each sample were transferred (1.0 ml) aseptically into sterile Petri plates and thereafter 10 to 15 ml of molten Violet Red Bile Agar (VRBA) was added and the plates were incubated at 37±0.5°C for 24-48 h and the number of colony forming units (cfu) was noted.

2.5.4 Textural analysis of paneer:

Textural parameters such as hardness, cohesiveness, adhesiveness and springiness was determined in paneer samples using texture analyser, Lloyd Instrument, Hampshire, UK (Model No. 01/2962) equipped with 5 KN load-cells with a speed of 20 rpm. The instrument was set with a tensile and compressive load of 4900 N and 4000 N, respectively. The measurements were carried out in a room maintained at 23±1°C temperature and 65±1 per cent RH. The samples were cut into 1±0.006 cm³ and placed in the compression support plate in such a manner that fibres were oriented perpendicular to the cylindrical compression anvil.

3 Results and discussion:

The fresh samples of paneer prepared using ohmic heated milk as well as conventional heating were analysed for various compositional and textural parameters. The samples were also subjected to storage study at refrigeration conditions ($7\pm 1^\circ\text{C}$) and analysed for various quality characteristics such as changes in acidity, sensory scores and microbial counts.

3.1 Compositional Analysis of Paneer:

The average data obtained for various compositional parameters of paneer samples were as shown in table 2. The values of moisture, fat, protein, lactose and ash content of ohmically treated paneer samples were 49.69, 25.51, 21.22, 2.29 and 1.30 per cent, respectively, which was in accordance to the values specified by [17]. Moreover, the statistical analysis of the values suggested that there was no significant ($p>0.05$) difference between the composition of ohmically treated samples compared to conventionally heated samples. The observations of the present study indicated that the composition of milk heated using ohmic treatment was similar to the one using conventional methods, which may be the reason for similar values of composition in paneer samples. [18] reported that the milk quality, specifically the protein denaturation, is one of the important factors influencing the yield and composition of paneer. There are limited reports available for the compositional characters of paneer prepared from milk samples treated with ohmic heating. [19] studied the degree of protein denaturation in ohmic and conventionally heated milk samples. The results indicated that there was no significant difference in the degree of protein denaturation in the samples prepared using different heating (ohmic and conventional) method.

Table 2: Compositional analysis of paneer

Mode of heating milk	Parameters (%)				
	Moisture	Fat	Protein	Lactose	Ash
Conventional	49.98 \pm 0.41	25.36 \pm 0.15	21.13 \pm 0.11	2.25 \pm 0.08	1.29 \pm 0.01
Ohmic	49.69 \pm 0.35	25.51 \pm 0.18	21.22 \pm 0.15	2.29 \pm 0.06	1.30 \pm 0.01

*Mean \pm SD, values are means of three observations

3.2 Textural Analysis of Paneer:

Paneer, being a variety of cheese, its rheological properties is an important factor with respect to its processing parameters, yield and quality. The paneer samples prepared using two different heating techniques (conventional and ohmic) were analysed for various textural parameters (hardness, cohesiveness, springiness, adhesiveness, gumminess and chewiness) using instrumental method and the results are presented in Table 3. The firmness (hardness) of a product determines its capacity to cut or slice, but the inherent elasticity of paneer can be interpreted with its springiness. For this reason, the hardness and springiness of paneer are especially important. The textural analysis of the samples prepared using conventional heating showed the values for hardness, cohesiveness, springiness, adhesiveness, gumminess and chewiness as 15.17 N, 0.39, 6.94 mm, 1.69 Nmm, 5.69 N and 32.90 Nmm, respectively; whereas the values for samples prepared using ohmic treatment were 16.08 N, 0.41, 7.10 mm, 1.72 Nmm, 5.62 N and 33.67 Nmm, respectively. Paneer prepared using milk heated by conventional method had significantly ($P \leq 0.05$) higher values for hardness and chewiness as compared to samples prepared using ohmic heating. The statistical analysis of the data obtained for the rheological parameters for both (conventional and ohmic) treatments showed that the values for cohesiveness, springiness, adhesiveness and gumminess were significantly ($p > 0.05$) similar with each other in all the samples. [18] showed texture analysis of ohmic and conventional heated paneer and results showed that significant difference as ohmic heated paneer exhibited less hardness.

Table 3: Textural analysis of paneer

Mode of heating milk	Parameters					
	Hardness (N)	Cohesiveness	Springiness (mm)	Adhesiveness (Nmm)	Gumminess (N)	Chewiness (Nmm)
Conventional	16.08±0.06 ^a	0.41±0.14 ^a	7.10±0.07 ^a	1.72±0.04 ^a	5.62±0.04 _a	33.67±0.12 ^a
Ohmic	15.77±0.08 ^b	0.39±0.11 ^a	6.94±0.05 ^a	1.69±0.04 ^a	5.69±0.06 _a	32.90±0.14 ^b

*Mean±SD, values are means of three observations
a,b Means within columns with different superscript letters are significantly different ($p < 0.05$) from each other.

3.4 Sensory Evaluation of Paneer During Storage

Two different heating treatments viz., conventional and ohmic was studied for the processing of milk and using it for paneer making. The prepared samples were evaluated for the effect of heating treatment on sensory characteristics (flavour, colour & appearance and body & texture) and the results are presented in Table 4. The flavour scores for the freshly prepared samples show that both the samples made from conventional and ohmically heated milk was highly accepted by the sensory panel. The flavour scores for both the samples decreased significantly during the storage study, however, the samples were readily accepted until 18th day of storage. The panel found that the flavour scores of the conventionally treated sample (28.13) was below the acceptance level, whereas, the ohmically treated sample was still accepted at the end of storage study with a flavour score of more than 29, as suggested by **BIS 1981**.

The body and texture scores of the sample prepared using ohmic heating was slightly higher compared to the paneer prepared using conventional heating at the onset of the storage period. However, there was marginal decrease in score throughout the storage study in all the samples.

The colour and appearance scores in all the freshly prepared samples were significantly ($p>0.05$) at par with each other in freshly prepared products, suggesting that the mode of heat treatment was not having any effect on appearance characteristics of the product.

The overall acceptance scores of the samples indicated that fresh paneer samples, irrespective of the heat treatment were highly acceptable to the panel. However, the scores concomitantly decreased during the storage study and at the end of 21st day, the sample prepared by ohmic heating was having slightly higher scores compared to the sample prepared using conventional heating. **[18]** studied the comparisons of conventional and ohmic heated paneer and found that overall acceptability score was found to be lowest in conventional heated paneer.

Table 4: Sensory score of paneer during storage at 7±1°C

Sensor y attribute	Mode of heating milk	Storage period (days)							
		0	3	6	9	12	15	18	21
Flavour	Conv entio nal	45.24 ±0.9 ^{2a} A	43.48 ±0.99 ^a B	41.21 ±1.08 ^a C	39.61± 0.91 ^{aC} D	38.33 ±0.83 ^a DE	36.97 ±1.04 ^a E	35.11 ±0.89 ^a F	28.13 ±0.73 aG
	Ohmi c	45.85 ±0.87 aA	44.14 ±1.15 ^a B	41.54 ±0.97 ^a C	40.03± 0.96 ^{aC} D	39.12 ±0.94 ^a DE	37.59 ±0.97 ^a EF	36.51 ±0.92 ^a F	29.35 ±0.77 aG
Bod y and texture	Conv entio nal	32.81 ±0.34 aA	32.55 ±0.27 ^a AB	30.62 ±0.30 ^a BC	29.54± 0.24 ^{aC} D	28.31 ±0.21 ^a DE	27.56 ±0.25 ^a DE	26.42 ±0.19 ^a EF	25.22 ±0.22 aF
	Ohmi c	33.68 ±0.29 aA	32.81 ±0.22 ^a AB	31.22 ±0.25 ^a BC	29.82± 0.19 ^{aC} DE	29.14 ±0.24 ^a DEF	28.08 ±0.22 ^a EFG	27.35 ±0.21 ^a FG	26.31 ±0.23 aG
C and A	Conv entio nal	9.51± 0.08 ^a A	9.12± 0.07 ^a AB	8.68± 0.10 ^{aB} C	8.52±0 .08 ^{aCD}	8.42± 0.07 ^{aC} D	8.23± 0.08 ^{aC} D	8.14± 0.07 ^{aD}	7.58± 0.09 ^a E
	Ohmi c	9.49± 0.11 ^a A	9.08± 0.06 ^{aA} B	8.62± 0.11 ^{aB} C	8.47±0 .10 ^{aCD}	8.40± 0.08 ^{aC} D	8.19± 0.09 ^{aC} D	8.11± 0.09 ^{aD} E	7.66± 0.10 ^a E
Tot al score*	Conv entio nal	92.56 ±0.87 aA	90.15 ±0.81 ^a B	85.51 ±0.91 ^a C	82.67± 0.88 ^{aD}	80.06 ±0.79 ^a E	77.76 ±0.92 ^a F	74.67 ±0.77 ^a G	65.93 ±0.75 aH
	Ohmi c	94.02 ±0.73 bA	91.03 ±0.85 ^a B	86.38 ±0.86 ^a C	83.32± 0.83 ^{aD}	81.66 ±0.85 ^b D	78.86 ±0.87 ^b E	76.97 ±0.74 bE	68.32 ±0.78 bF
<p>* Score of 5 for package is added to the total score * Mean±SD, Values are means of three observations *C and A: Color and appearance A,B,C,D Means within rows with different uppercase superscript letters are significantly different (p<0.05) from each other. a-b, Means within columns with different lowercase superscript letters are significantly different (p<0.05) from each other.</p>									

3.5 Acidity of Paneer During Storage

Acidity of milk and milk products is an important criterion to judge the freshness of the products and hence, the paneer samples prepared using the milk heated

with conventional as well as ohmic heating were analysed for the change in acidity during storage at $7\pm 1^{\circ}\text{C}$. The results presented in Table 5, shows that acidity of fresh samples of paneer prepared from conventional and ohmic heating was 0.541 and 0.545 per cent lactic acid (LA), respectively. It was also observed that there was increase in acidity of all the samples during the storage, however, the increase was more intense towards the end of storage study.

Table 5: Acidity of paneer during storage

Mode of heating milk	Acidity (%LA) during storage (days)							
	0	3	6	9	12	15	18	21
Conventional	0.541± 0.008 ^a A	0.549± 0.011 ^a A	0.553± 0.008 ^a A	0.564± 0.011 ^a A	0.572± 0.012 ^a A	0.635± 0.012 ^a B	0.698± 0.013 ^a C	0.727± 0.011 ^a D
Ohmic	0.545± 0.006 ^a A	0.547± 0.009 ^a A	0.551± 0.010 ^a A	0.561± 0.009 ^a A	0.569± 0.010 ^a A	0.627± 0.011 ^a B	0.685± 0.011 ^b C	0.718± 0.012 ^a D
* Mean±SD, Values are means of three observations A,B,C,D Means within rows with different uppercase superscript letters are significantly different ($p<0.05$) from each other. a-b, Means within columns with different lowercase superscript letters are significantly different ($p<0.05$) from each other.								

Acidity in samples significantly ($P>0.05$) increased after 15th day of storage in all the samples. The difference in acidity values throughout the storage study was non-significant among the samples prepared using two different heating techniques, concluding that the mode of heating had no effect on changes in acidity of the paneer during the storage study.

[20] evaluated the paneer samples prepared from buffalo milk for changes in acidity during the storage study at $7\pm 1^{\circ}\text{C}$. The results of their study indicated that the acidity in fresh samples was 0.31 (% LA) which increased to 0.59 (% LA) during storage. The authors suggested that the increase in acidity of the samples may be due to increase in bacterial growth during storage, which is affected by milk quality and milk processing treatments. [21] recently prepared the paneer samples using toned milk and studied the changes in acidity during storage at refrigeration temperature. The observation showed that fresh paneer samples had the acidity 0.491(%LA) and the values increased to 0.976 (%LA) at 9th day of storage. The factors affecting the increase in acidity, as suggested

by the authors were microbial load of the milk, method of manufacturing the paneer and storage conditions.

3.6 Microbiological Analysis of Paneer During Storage

Microbial quality of food and dairy products depicts the various aspects involved in the preparation of the product including raw material, processing parameters, design of equipment, etc. and hence, the microbial load can be used as a tool to grade the quality of processed food. The microbiological examination of the paneer samples prepared with the milk heated using ohmic heater was evaluated and the results were compared with the samples prepared by conventional heating of milk during the storage at 7 ± 1 °C. The data presented in table 6 and 7 shows the changes in aerobic plate count (APC) and yeast & mold counts (Y&M), respectively.

The analytical results of the prepared samples suggested that the APC counts of fresh samples prepared using conventional and ohmic heating of milk were 2.87 and 2.73 log cfu/g. The statistical analysis of the data shows that the counts increased significantly ($p<0.05$) throughout the storage period in all the studied samples, with higher rate of increase in counts were observed during the later stage of the study (15th and 21th day). However, there was no significant ($p<0.05$) difference between the APC in the ohmically and conventionally treated samples.

Table 6: APC (log cfu/g) of paneer during storage

Mode of heating milk	Storage period (days)				
	0	3	9	15	21
Conventional	2.87±0.05 ^a A	3.11±0.09 ^a A	3.38±0.09 ^a B	3.87±0.06 ^a C	5.34±0.08 ^a D
Ohmic	2.73±0.08 ^a A	3.04±0.05 ^a B	3.31±0.05 ^a B	3.71±0.08 ^a C	5.26±0.07 ^a D
	* Mean±SD, Values are means of three observations A-B, Means within rows with different uppercase superscript letters are significantly different ($p<0.05$) from each other. a-b, Means within columns with different lowercase superscript letters are significantly different ($p<0.05$) from each other.				

Table 7: Yeast and mold count (log cfu/g) of Paneer

Mode of heating milk	Storage period (days)				
	0	3	9	15	21
Conventional	1.77±0.07 ^a A	1.82±0.07 ^a A	1.91±0.07 ^a A	2.23±0.06 ^a B	2.84±0.08 ^a C
Ohmic	1.70±0.06 ^a A	1.76±0.09 ^a A	1.85±0.09 ^a A	2.14±0.08 ^a B	2.72±0.05 ^a C
	* Mean±SD, Values are means of three observations A,B,C Means within rows with different uppercase superscript letters are significantly different (p<0.05) from each other. a-b, Means within columns with different lowercase superscript letters are significantly different (p<0.05) from each other.				

Similarly, the results for Y&M shows that the freshly prepared paneer samples using conventional and ohmic heating of milk were having the counts as 1.77 and 1.70 log cfu/g. The Y&M in all the samples increased significantly ($p > 0.05$) during the storage period in the samples prepared by conventional as well as ohmic heating. In addition, there was no significant difference in Y&M for the paneer samples prepared using conventional and ohmic treatment. Moreover, all the samples (conventional and ohmic) were free from coliform colonies throughout the storage study, suggesting that both the heat treatment were sufficient for the destruction of coliforms and no post processing contamination have been occurred in the samples. [22] also observed similar results for paneer samples prepared from mixed milk for various microbiological characterization including APC, coliform and Y&M during storage at refrigeration temperature. The authors reported that the APC count were significantly increasing during the storage period where the value of fresh samples was 3.53 log cfu/g and reached to 6.76 log cfu/g on 14th day of storage. The Y&M counts were also increased from 2.23 to 4.46 log cfu/g after 14th day of storage. However, the coliform counts were absent in the samples throughout the storage period. Recent studies involving microbiological screening of paneer samples during storage has been done by various researchers and suggested that as the product is prepared in open condition (batch method), the samples is vulnerable for environmental contamination and hence, the product should be prepared in a hygienic condition. Many factors such as quality of milk, heating method, utensils involved in making paneer, packaging material, storage temperatures, etc. have been reported as to affect the microbiological quality of paneer. Moreover, the APC and Y& M count has been reported top increase during the storage as an inherent

character of the paneer, whereas, the coliform count, considered as a post processing contamination should be absent in samples prepared under utmost hygienic conditions and low storage temperature [21] [23] [24].

Conclusion:

The study successfully depicts that milk can be heated in continuous ohmic heater at 80°C for no hold condition with applied voltage supplied to heater as 137.7 V (stage-1) and 72.2V(stage-2) with 1.5 l/min flowrate. Paneer samples were prepared using the ohmic heating of milk and the results for physico-chemical and microbial analysis were compared with the conventionally prepared samples. However, the paneer had better textural characters in terms of hardness and chewiness when it was prepared using ohmically heated milk. The data for storage study indicated that the paneer samples prepared using ohmic heating were acceptable sensory quality up to 18th days. In addition, compositional, sensory and microbial analysis of paneer showed similar values for samples prepared using milk heated by ohmic and conventional method throughout the storage study, however, the ohmic heating resulted in slight superior results in terms of texture and sensory attributes. The ohmic heating technology results in a good quality paneer while ensuring food safety and improved manufacturing processes and hence can be an effective tool as a substitute to conventional processing in dairy and food industries.

REFERENCES:

- [1] Bolhuis, D., Mosca, A. C., & Pellegrini, N. (2022). Consumer awareness of the degree of Industrial Food Processing and the Association with Healthiness—A Pilot Study. *Nutrients*, 14(20), 4438.
- [2] Kumar, M., & Hausain, A. (2014). Effect of ohmic heating of buffalo milk on microbial quality and texture of paneer. *Asian Journal of Dairying & Foods Research*, 33(1), 9-13.
- [3] Knirsch, M. C., Dos Santos, C. A., de Oliveira Soares, A. A. M., & Penna, T. C. V. (2010). Ohmic heating—a review. *Trends in food science & technology*, 21(9), 436-441.
- [4] Alkanan, Z. T., Altemimi, A. B., Al-Hilphy, A. R., Watson, D. G., & Pratap-Singh, A. (2021). Ohmic heating in the food industry: Developments in concepts and applications during 2013–2020. *Applied sciences*, 11(6), 2507.

- [5] Fillaudeau, L., Winterton, P., Leuliet, J. C., Tissier, J. P., Maury, V., Semet, F., ... & Chopard, F. (2006). Heat treatment of whole milk by the direct joule effect— experimental and numerical approaches to fouling mechanisms. *Journal of dairy science*, 89(12), 4475-4489.
- [6] Ayadi, M.A., Benezech, T., Chopard, F., Berthou, M., Leuliet, J.C. (2005a). Heat treatment of dairy product by a flat ohmic cell: impact of the Reynolds number, fluid rheology and deposit presence on the electrode surface temperature. Heat Exchanger Fouling and Cleaning: Challenges and Opportunities, Engineering Conferences Intl.; Kloster Irsee, Germany; June 5–10: Engineering Conferences International, New York, U. S. A 2005
- [7] Biss, C. H., Coombes, S. A., & Skudder, P. J. (1989). Development and application of ohmic heating for the continuous heating of particulate foodstuffs. *Process engineering in the food industry: developments and opportunities*/edited by RW Field and JA Howell.
- [8] Rathva, A., Patel, S., Pinto, S., Chauhan, I., & Patel, S. (2024). Design and development of continuous ohmic heater for Milk and its performance study. *European Journal of Nutrition & Food Safety*, 16(7), 43–55.
- [9] De, S. (1980). *Outlines of dairy technology*. Outlines of Dairy Technology. Pp. 382-466, Oxford university press, Delhi.
- [10] BIS (1983). *ISI Handbook of Food Analysis -Dairy Products IS: IS 10484 (Part XI)*, Bureau of Indian Standards, Manak Bhawan, New Delhi.
- [11] Indian Standard: 2785-1979 (Reaffirmed 1995). *Specification for Natural cheese (Hard Variety), Processed Cheese, Processed Cheese Spread and Soft Cheese*. Bureau of Indian Standards, Manak Bhavan, New Delhi.
- [12] Indian Standard: 1547 (1985). *Specifications for Infant Milk Foods*. Bureau of Indian Standards, Manak Bhavan, New Delhi.
- [13] Indian Standard: 10484 (1983). *Specification for Paneer*. Bureau of Indian Standards, Manak Bhavan, New Delhi, 1-11.
- [14] BIS (1983). *ISI Handbook of Food Analysis -Dairy Products IS: IS 10484 (Part XI)*, Bureau of Indian Standards, Manak Bhawan, New Delhi.

- [15] Hartman, P. A., and LaGrange W. S. (1985). Coliform bacteria. Standard Methods for the Examination of Dairy Products. *15th ed. G. H. Richardson, ed. American Public Health Association, Washington, DC, 173–187*
- [16] Messer, J. W., Behney, H. M., & Leudecke, L. O. (1985). Microbiological count methods. In: H. Richardson (Ed.) Standard methods for the examination of Dairy Products. A. P. H. A., Washington, DC.
- [17] FSSAI (2020). Food Safety and Standards (Food Products Standards and Food Additives), Food Safety and Standard Authority of India, Ministry of Health and Family Welfare, Government of India, New Delhi.
- [18] Kumar, J. P., Ramanathan, M., & Ranganathan, T. V. (2014). Ohmic heating technology in food processing—A review. *International Journal of Food Engineering and Technology*, 3, 1236-1241.
- [19] Sun, H., Kawamura, S., Himoto, J. I., Itoh, K., Wada, T., & Kimura, T. (2008). Effects of ohmic heating on microbial counts and denaturation of proteins in milk. *Food science and technology research*, 14(2), 117-123.
- [20] Rai, S., Goyal, G. K., & Rai, G. K. (2008). Effect of Modified Atmosphere Packaging (MAP) and storage on the chemical quality of paneer. *Journal of Dairying, Foods and Home Sciences*, 27(1), 33-37.
- [21] Mishra, D., & Rao, J. (2022). Chemical quality changes in ajwain paneer during storage. *The Pharma Innovation Journal*, 11(7): 4133-4135.
- [22] Eresam, E. K. K., Pinto, S., & Aparnathi, K. D. (2015). Concise and informative title: evaluation of selected spices in extending shelf life of paneer. *Journal of Food Science and Technology*, 52, 2043-2052.
- [23] Prajapati, S., Kumar Malladevanahalli Huchegowda, S., Hosapalya Chikkathimmaiah, D., Rao, K. J., Shaik, A. H., Champalli Shankara Reddy, R., & Sabikhi, L. (2022). Effect of ionic silver solution on Paneer (Indian cottage cheese) quality and shelf life. *International Journal of Dairy Technology*, 75(4), 902-909.
- [24] Qureshi, T. M., Nadeem, M., Iftikhar, J., Ibrahim, S. M., Majeed, F., & Sultan, M. (2023). Effect of Traditional Spices on the Quality and Antioxidant Potential of Paneer Prepared from Buffalo Milk. *Agriculture*, 13(2), 491.

UNDER PEER REVIEW